

High quality sandblasting cabin for cleaning, deburring, roughening, derusting, matting etc.

Sablux Technik AG
Bramenstrasse 14
CH-8184 Bachenbülach
Schweiz
Tel. 043 411 44 22
Fax : 043 411 44 23
technik@sablux.ch
<http://www.sablux.ch>

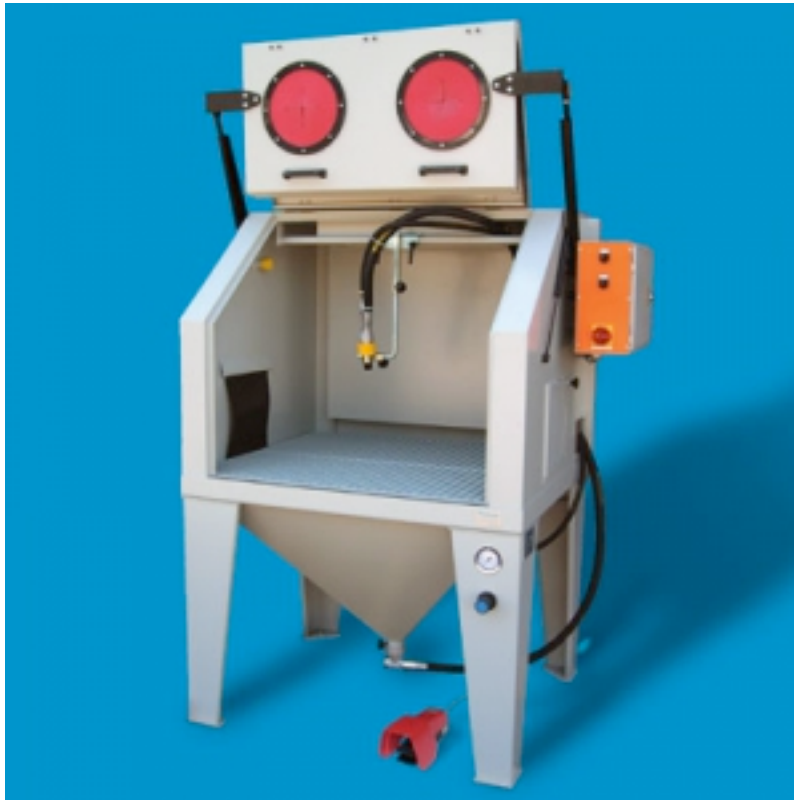

Standard Equipment :

- Sandblasting gun type "Power shot" 100 with sand nozzle in boron carbide \varnothing 10mm and air nozzle in stainless steel \varnothing 4mm
- Floor grating in two parts, capacity approximately 200 kg surface load
- Gun holder
- Drain cup
- Hand holes sealed twice with wear proof special rubber
- Electrical foot pedal with protective hood IP65
- Without blind spot, double glazing with attrition-proof glass
- Switchbox mounted on the right of the cabin (dustproof)
- Safety switch
- Manometer
- Pressure reducing valve

Options :

- Tumbling basket aggregate, basket \varnothing 565mm with various hole
- Double tumbling basket aggregate, baskets available with various hole
- Manual turntable \varnothing 600 mm / \varnothing 750 mm
- Electrical turntable \varnothing 600 mm / \varnothing 750 mm
- Different dust separators

Technical data

Sablux Technik AG
Bramenstrasse 14
CH-8184 Bachenbülach
Schweiz
Tel. 043 411 44 22
Fax : 043 411 44 23
technik@sablux.ch
http://www.sablux.ch

Exterior dimensions :	Width	1'441 mm
	Depth	1'067 mm
	Height	1'762 mm (closed cabin) 2'300 mm (opened cabin)
Interior dimensions :	Width	1'145 mm
	Depth	890 mm 970 mm (without ascending sifter)
	Height	780 mm
	Weight :	Approximately 250 kg
Pressure air connection:	G $\frac{3}{4}$ with screw coupling. 19mm inside diameter	
Air consumption :	Approximately 40 m ³ /h at 4bar	
Electrical connection :	3 x 400V / 50Hz	
Dust exhaust :	Connecting adapter at the back wall \varnothing 100mm	

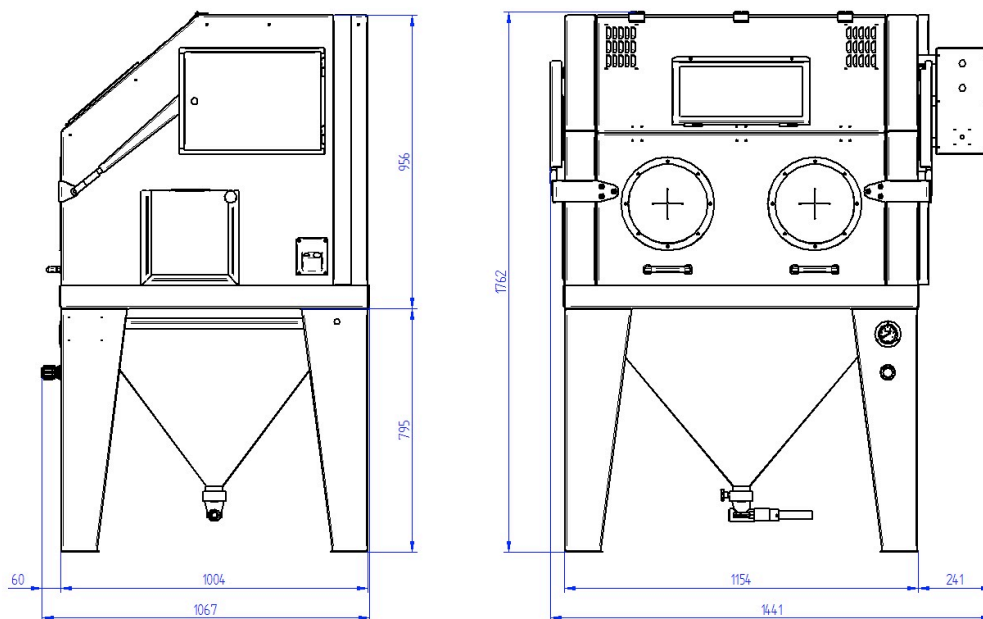

Sablux SX 115 S