



**Standard Equipment :**

- Sandblasting gun type "Power shot" 140 with sand nozzle in boron carbide  $\varnothing$  11mm and air nozzle in stainless steel  $\varnothing$  5mm
- Floor grating in three parts, capacity approximately 340 kg surface load
- Gun holder
- Drain cup
- Hand holes sealed twice with wear proof special rubber
- Electrical foot pedal with protective hood IP65
- Without blind spot, double glazing with attrition-proof glass
- Switchbox mounted on the right of the cabin (dustproof)
- Safety switch
- Manometer
- Pressure reducing valve

**Options :**

- Tumbling basket aggregate, basket  $\varnothing$  565mm with various hole
- Double tumbling basket aggregate, baskets available with various hole
- Manual turntable  $\varnothing$  600 mm /  $\varnothing$  750 mm
- Electrical turntable  $\varnothing$  600 mm /  $\varnothing$  750 mm
- Different dust separators

## Technical data

Sablux Technik AG  
Bramenstrasse 14  
CH-8184 Bachenbülach  
Schweiz  
Tel. 043 411 44 22  
Fax : 043 411 44 23  
technik@sablux.ch  
http://www.sablux.ch

Exterior dimensions :	Width	1'841 mm
	Depth	1'064 mm
	Height	1'763 mm (closed cabin) 2'300 mm (opened cabin)
Interior dimensions :	Width	1'545 mm
	Depth	890 mm 970 mm (without ascending sifter)
	Height	780 mm
	Weight :	Approximately 340 kg
Pressure air connection:	G $\frac{3}{4}$ with screw coupling. 19mm inside diameter	
Air consumption :	Approximately 60 m <sup>3</sup> /h at 4bar	
Electrical connection :	230/400V / 50Hz	
Dust exhaust :	Connecting adapter at the back wall $\varnothing$ 100mm	

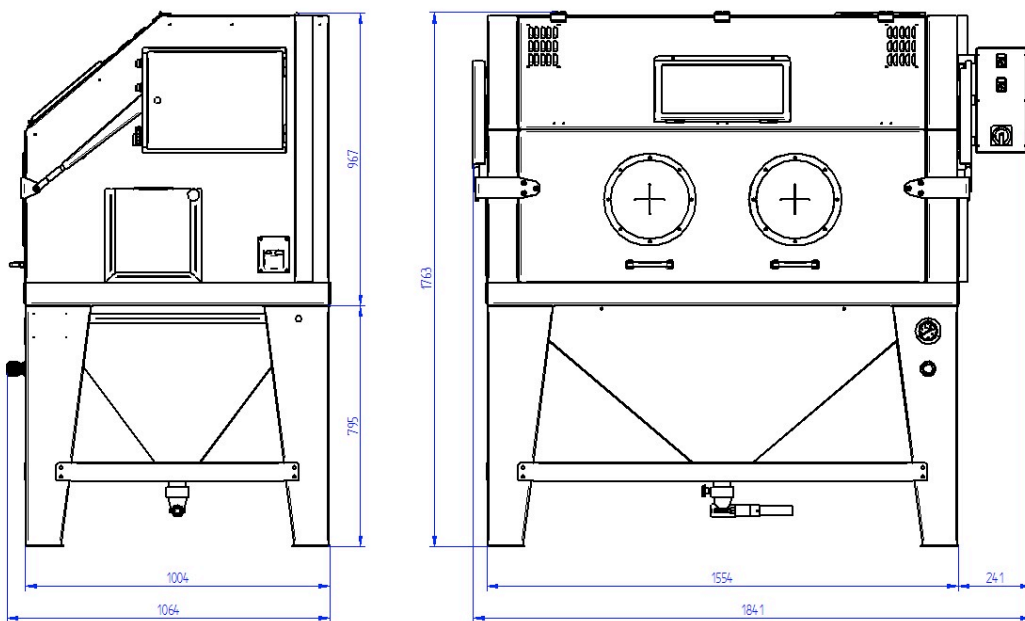

# Sablux SX 155 S